

### Beam Clamp TCS 41 HCP

Group: 1837

#### Application

The Beam Clamp TCS 41 allows for a direct connection of Sikla 41mm slotted strut channel without having this obstruction. If the channel opening is supposed to be in beam direction, the Beam Clamp TCS 41 can easily be fixed within the channel's opening as we know it from type TCS 1.

#### Scope of delivery

Cast iron part, completely pre-assembled with clamping bolt and locking nut.

#### Installation

Insert the foot of the Beam Clamp into the slot on the back of the channel, twist by 90° and push it against the beam's flange. First tighten bolt of Beam Clamp (hand-tight), then tighten further with 1 1/2 turns. The sharpened tip of the bolt will dent the beam thus providing a high level of safety. At last tighten locking nut. Every channel (statically determined) has to be fixed at least twice.

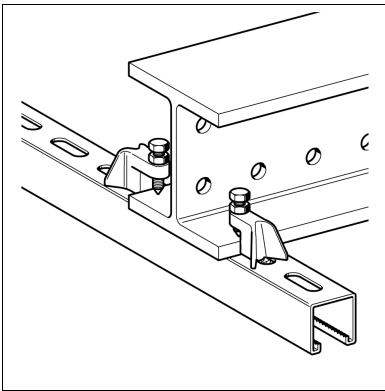

#### Technical Data

Nominal load: 4.0 kN

Material: Cast iron, HCP

Type	Clamping range on parallel flange [mm]	W [kg]	Quantity [pack]	Part number
TCS 41	20	0.12	50	<b>110003</b>

