

### Middle Clip PV 1-M

Group: E314

#### Application

Middle fastening and assembly block for all typical framed Photovoltaic panels to be used with high loads caused by wind suction. Suits panel thicknesses (H) of 35 - 50 mm for any angle. Bimetal corrosion resistance, by using seal-coating on the support (washer and sleeve). Clamping forces applied at outer edge of panel to prevent undue tensioning of glass.

#### Scope of delivery

Fully assembled unit comprising Speed Nut, Support and Clip. No loose parts.

#### Installation

Fix Middle Clip into the required position by pressing the Speed Nut into the channel. Slide the Middle Clip along the channel so that it grips onto the existing PV panel already in position. Put the next panel on the frame and tighten the Middle Clip with max 10 Nm.

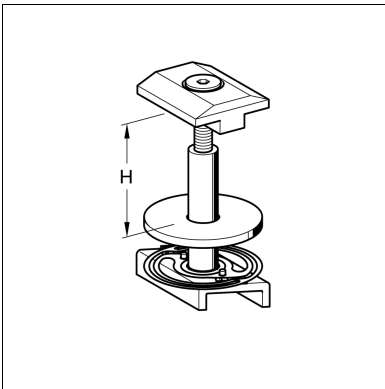

#### Technical Data

adm. shear force 90° to panel surface: 1.0 kN/clip

adm. tensile load: 3.2 kN/clip

Material:

Clip: Aluminium

Screw: Stainless steel 304

Stud bolt, Washer and Speed Nut: HCP

Type	Panel thickness [mm]	W [kg]	Quantity [pack]	Part number
PV 1-M	35 - 50	0.09	50	199510