

Bulb Flat Steel Beam Clamp

Group: 1837

Application

Solid connection element to fix pipework, electrical containment services to flat-steel bulk profiles.

May also be used for assemblies after the welding process or repair works to the steel profile. Possible to use as a single fixing or to assemble cross beams for multiple connections. No damage of the coating during installation.

Scope of delivery

Pre-assembled unit with hexagon bolt.

Installation

Tighten the bolt with max. 40 Nm torque. Connections made to M10 female thread.

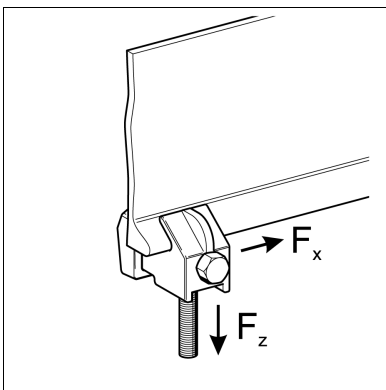

Technical Data

For bulb profiles from 80 to 120 mm

F_z adm. = 4.0 kN

F_x adm. = 2.0 kN

Material:

Main material: Malleable iron

Bolt: 8.8, galvanised

Type	Connection	W [kg]	Quantity [pack]	Part number
WFK	M10	0.41	20	198056

