

End Clip PV-E

Group: E314

Application

Edge fastening and assembly block for all typical framed Photovoltaic panels. Suits panel thicknesses of 28 - 50 mm for any angle. Bimetal corrosion resistance, by using seal-coating on the support (washer and sleeve). No gap occurs between the frame and End clip, when using form lock clip. Clamping forces applied at outer edge of panel to prevent undue tensioning of glass.

Scope of delivery

Fully assembled unit comprising Speed Nut, Support and Clip.

Installation

Insert Speed Nut into the open channel slot at any position required. Adjust the bolt into the right position (90° to channel) and tighten it with max. 15 Nm by using standard bit (hexagon socket 4mm, Form C8). The exact position of the bolt gives a strong end-stop for fixing the first panels. Put the L-clip on the top of the assembly, put the panel against the bolt and tighten the L-clip over the panel frame with a setting torque of 3 Nm max.

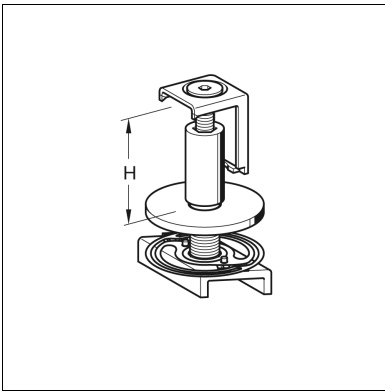

Technical Data

Prevention of panel slip and tension load up to 1.5 kN per Clip.

Material:

Clip and screw: Stainless steel A2

Bolt, Washer and Speed Nut: HCP

Type	Panel thickness [mm]	W [kg]	Quantity [pack]	Part number
PV-E 28 - 50	28 - 50	0.10	50	193297

