

41/21/2,0

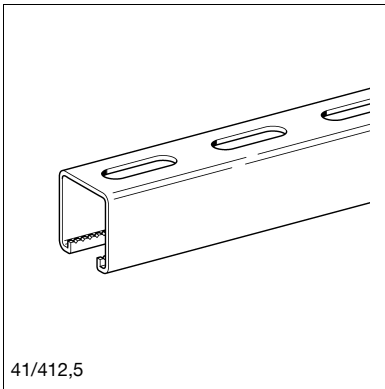

41/412,5

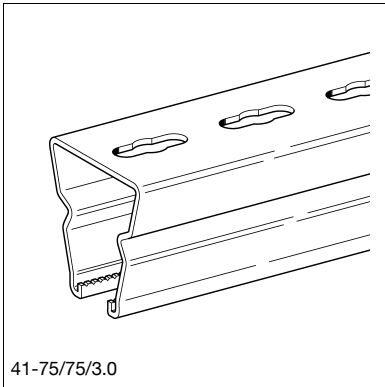

41-75/75/3,0

Channel MS 41 HCP

Group: 1811

Application

Element for easily and efficiently pre-assembling crossbars, wall brackets and supporting structures on construction sites or in workshops.

Scope of delivery

Available as single or double channels.
Double channels are joined together by clinching.

Installation

All Channels MS 41 hcp are serrated inside and provide numerous combination options with other high corrosion protected system components.

Technical Data

Material: Steel, HCP

D = Double channel

Type W/H/th [mm]	Section modulus [cm ³]	Moment of inertia [cm ⁴]	Radius of gyration [cm]
41/21/2.0	W _y : 0.82	I _y : 0.92	i _y : 0.75
	W _z : 2.11	I _z : 4.32	i _z : 1.64
41/31/2.0	W _y : 1.61	I _y : 2.55	i _y : 1.10
	W _z : 2.90	I _z : 5.96	i _z : 1.69
41/41/2.0	W _y : 2.50	I _y : 5.21	i _y : 1.44
	W _z : 3.65	I _z : 7.48	i _z : 1.73
41/41/2.5	W _y : 2.94	I _y : 6.17	i _y : 1.44
	W _z : 4.39	I _z : 9.01	i _z : 1.72
41/62/2.5	W _y : 5.75	I _y : 18.08	i _y : 2.10
	W _z : 6.29	I _z : 12.91	i _z : 1.77
41-75/75/3.0	W _y : 10.29	I _y : 44.30	i _y : 2.53
	W _z : 11.41	I _z : 42.80	i _z : 2.48
41/21/2.0 D	W _y : 2.35	I _y : 4.94	i _y : 1.24
	W _z : 4.22	I _z : 8.65	i _z : 1.64
41/41/2.5 D	W _y : 8.96	I _y : 36.73	i _y : 2.46
	W _z : 8.79	I _z : 18.03	i _z : 1.72
41-75/75/3.0 D	W _y : 30.66	I _y : 230.02	i _y : 4.07
	W _z : 22.83	I _z : 85.60	i _z : 2.48

Type W/H/th [mm]	Cross section A [cm ²]	Distance e [cm]	Max. point carrying capacity F _{max} [kN]	Max. torsional moment M _q [Nm]
41/21/2.0	1.60	1.11	4.0	44.5
41/31/2.0	2.08	1.58	4.0	44.5
41/41/2.0	2.48	2.07	4.0	44.5
41/41/2.5	3.03	2.09	6.0	44.5
41/62/2.5	4.08	3.14	6.0	44.5
41-75/75/3.0	6.92	4.30	10.0	44.5
41/21/2.0 D	3.20	2.10	4.0	44.5
41/41/2.5 D	6.06	4.10	6.0	44.5
41-75/75/3.0 D	13.84	7.50	10.0	44.5

Notice: All values take into account the perforation of the channels.
For load charts, see chapter "Pressix CC 41".

Approvals / Conformity



This product has obtained the "RAL Gütezeichen Rohrbofestigung" and is subject to external surveillance according to RAL GZ-655.

* = no RAL quality label

Type	Length [m]	Slot pattern	Weight [kg/m]	Qty. [m]	Part number
41/21/2.0	6	3	1.32	6	193860
41/31/2.0	6	3	1.64	6	198896
41/41/2.0	6	3	1.97	6	196724
41/41/2.5	6	3	2.36	6	161497
41/62/2.5	6	3	3.13	6	199527
41-75/75/3.0	6	4	5.68	6	174008
41/21/2.0 D *	6	3	2.64	6	193884
41/41/2.5 D *	6	3	4.74	6	166748
41-75/75/3.0 D *	6	4	11.24	6	173981