

### Block PB 27

Group: 2760

#### Application

Quick-installation element for efficient mounting of pipe clamps and other components to Sikla Channels MS 27:

- ◆ Time-saving due to pre-assembled Block instead of 2 individual parts.
- ◆ Retains position in horizontal and vertical channels during locational adjustment. But can still be moved easily and freely along the channel as required.
- ◆ To be combined with Pressix Rods PNS, threaded rods, screws or other products with a thread connection.

#### Scope of delivery

Block completely pre-assembled.

#### Installation

Insert the Block into the channel; by turning to the right, the channel nut locks into the channel, then tighten up to 10 Nm - That's it!

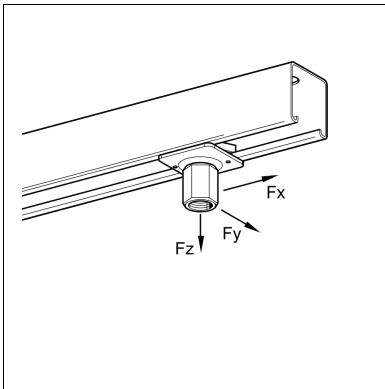

#### Technical Data

Fz = 1.5 kN

Fx = 0.8 kN

Material: Steel, electro-galvanised

Type	W [kg]	Quantity [pack]	Part number
M8	0.01	100	<b>195932</b>
M10	0.01	100	<b>117357</b>