

Assembly Group BG61 T100-1/2"

Group: 1102

Application

An Assembly Group containing components to make up a permanent pipe connection with the insulated Chilled Water Clamp RB for chiller plants and cool water systems. The Assembly Group is designed for use with the 100 beam system and steel beams up to a flange width of 100 mm. It is connected using the Assembly Set MS 5P, and the height is adjusted via the Threaded Tube 1/2".

Scope of delivery

Each Assembly Group is pre-assembled, packed and labeled.

Parts list:

- Item 1 Chilled Water Clamp RB
Assembly Kit MKit F 80 1/2" consists of:
- Item 2 Threaded Tube GR 1/2" x 200
- Item 3 Locking Nut NT G 1/2"
- Item 4 Mounting Plate GPL Stabil R1/2"-100
- Item 5 Beam Clip SPA 5P AU M12 HCP
Hexagon Bolt M12x60 HCP
Hexagon Nut M12 HCP
Washer HCP

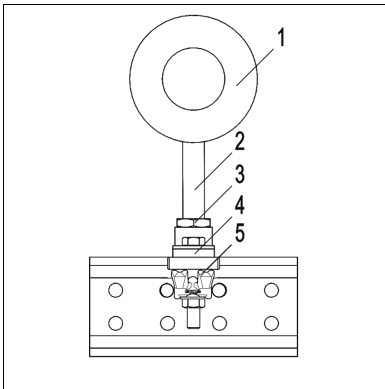

Installation

The assembly of the individual components to form an Assembly Group is carried out during the course of pipe installation on the construction site.

Technical Data

$L_{\text{max, vertical}} = 200 \text{ mm}$

$L_{\text{max, horizontal}} = 150 \text{ mm}$

Material:

- Connecting parts: Steel, HCP
- Bolts and nuts: Steel, HCP
- Insulating body: PUR foam (250 kg/m^3 , B2), $\mu = 1200$
 $\lambda = 0,045 \text{ W/mK (0}^\circ\text{C)}$

Area of use: $-50^\circ\text{C to }+105^\circ\text{C}$

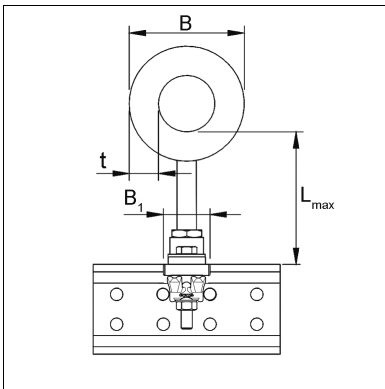

Type	Nominal widths [DN]	B ₁ [mm]	B [mm]	t [mm]	W [kg]	Quantity [pack]	Part number
21/30	15	50	81	30	1.65	1	112733
27/30	20	50	87	30	1.65	1	112734
33/30	25	50	93	30	1.66	1	112735
42/30	32	50	102	30	1.67	1	112736
48/30	40	50	108	30	1.67	1	112737
60/30	50	50	120	30	1.76	1	112738
76/30	65	50	136	30	1.88	1	112739
89/30	80	50	149	30	1.93	1	112740
114/40	100	50	195	40	2.51	1	112741