

15 ... 133

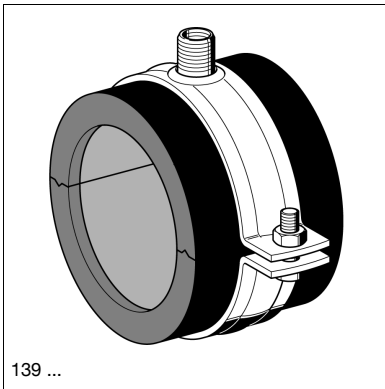

139 ...

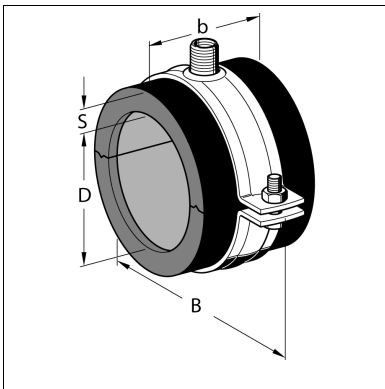

### Chilled Water Clamp LKS 19

Group: 1255

#### Application

Suitable for secure prevention of condensation water at the pipe support location of refrigeration and cold-water pipelines. An optimal diffusion-tight connection with the pipe insulation is easily and safely achieved by fixing usual insulation materials to the clamp faces using adhesive. Recommended up to  $-0^{\circ}\text{C}$  at normal ambient condition.

#### Scope of delivery

Consisting of pipe clamp and insulation insert. The one-piece insulation insert comprising two joined PUR elements forms a comprehensive connection between PUR element and pipe clamp all around the pipe. The outer edges of the PUR elements are equipped with elastomer foam and coated by a black aluminium foil.

Type	Nominal thickness of the insulation [mm]	Size	Length of PUR element b [mm]
LKS 19	19	15 - 89	50
		102 - 273	100

#### Technical Data

The unsupported lengths as listed in DIN 1988 may be applied for types LKS 13 and LKS M 19 to 168.

The regulations of DIN 4140 have to be respected (an existing gap has to be sealed with sealant). Sealant DP 30/45 see Chapter "Fixed Point Packages".

Clamp material:	Steel, electro-galvanised
Insulation insert:	Free of halogens
PUR core:	Specific gravity 80 or 120 $\text{kg/m}^3$
Thermal conductivity:	$\lambda = 0.024 - 0.026 \text{ W/(mK)}$ at $0^{\circ}\text{C}$
	$\lambda = 0.038 \text{ W/(mK)}$ at $10^{\circ}\text{C}$
	$\lambda = 0.040 \text{ W/(mK)}$ at $40^{\circ}\text{C}$
Steam diffusion resistance factor:	$\mu \geq 7000$
Fire resistance:	$E_1$ (DIN EN 13501-1)
Temperature range:	$-40^{\circ}\text{C}$ up to $+105^{\circ}\text{C}$
Insulation insert:	Up to 18 dB(A)
Storage temperature:	$\geq 10^{\circ}\text{C}$
Storage period:	1 year

\* = Delivery time: 10 workdays

Type	Pipe Ø D [mm]	B [mm]	Insulation thickness S [mm]	Thread connection	W [kg]	Quantity [pack]	Part number
LKS 19-15	15.0	91.5	19.0	M8/M10	0.08	42	114730
LKS 19-16 *	16.0	91.5	19.0	M8/M10	0.09	42	114731
LKS 19-18	18.0	99.0	19.5	M8/M10	0.09	42	114733
LKS 19-20 *	20.0	99.0	19.5	M8/M10	0.10	42	114734
LKS 19-22	22.0	105.0	19.5	M8/M10	0.10	42	114735
LKS 19-25	25.0	105.0	19.5	M8/M10	0.09	42	114736
LKS 19-26 *	26.0	105.0	19.5	M8/M10	0.09	42	114737
LKS 19-28	28.0	112.0	20.0	M8/M10	0.10	36	114738
LKS 19-30	30.0	112.0	20.0	M8/M10	0.10	36	114739
LKS 19-32 *	32.0	112.0	20.0	M8/M10	0.11	36	114740
LKS 19-35	35.0	125.0	20.0	M8/M10	0.17	24	114741
LKS 19-38	38.0	125.0	21.5	M8/M10	0.17	24	114742
LKS 19-40 *	40.0	134.0	21.5	M8/M10	0.18	24	114743
LKS 19-42	42.0	134.0	21.5	M8/M10	0.18	24	114744
LKS 19-44	44.5	134.0	21.5	M8/M10	0.20	24	114745
LKS 19-48	48.3	141.0	21.5	M8/M10	0.20	18	114746
LKS 19-50 *	50.0	146.5	21.5	M8/M10	0.20	18	114747
LKS 19-54	54.0	146.5	21.5	M8/M10	0.20	18	114748
LKS 19-57	57.0	146.5	22.0	M8/M10	0.22	18	114749
LKS 19-60	60.3	151.0	22.0	M8/M10	0.22	18	114751
LKS 19-64	64.0	151.0	22.0	M8/M10	0.22	18	114752
LKS 19-70	70.0	159.5	22.0	M8/M10	0.24	18	114753
LKS 19-76	76.1	173.0	22.0	M8/M10	0.30	18	114754
LKS 19-80	80.0	173.0	22.0	M8/M10	0.30	18	114755
LKS 19-89	88.9	186.0	22.0	M8/M10	0.30	10	114756
LKS 19-102	101.6	203.0	22.5	M8/M10	0.39	10	114757
LKS 19-108	108.0	203.0	22.5	M8/M10	0.40	10	114758
LKS 19-110	110.0	203.0	22.5	M8/M10	0.40	10	114759
LKS 19-114	114.3	215.0	22.5	M8/M10	0.41	8	114760
LKS 19-125 *	125.0	229.0	23.0	M8/M10	0.45	6	114761
LKS 19-133	133.0	229.0	23.0	M8/M10	0.47	6	114762
LKS 19-139	139.7	265.0	23.0	M12/M16 <sup>1</sup> / <sub>2</sub> "	1.19	6	114763
LKS 19-160	159.0	276.0	23.0	M12/M16 <sup>1</sup> / <sub>2</sub> "	1.27	6	114764
LKS 19-168	168.3	287.0	23.0	M12/M16 <sup>1</sup> / <sub>2</sub> "	1.29	6	114765
LKS 19-180	180.0	307.0	25.0	M12/M16 <sup>1</sup> / <sub>2</sub> "	1.35	6	114766
LKS 19-200	200.0	321.0	25.0	M12/M16 <sup>1</sup> / <sub>2</sub> "	1.44	6	114767
LKS 19-219	219.0	344.0	23.0	M12/M16 <sup>1</sup> / <sub>2</sub> "	1.62	6	114768
LKS 19-225	225.0	355.0	25.0	M12/M16 <sup>1</sup> / <sub>2</sub> "	1.64	6	114769
LKS 19-250	250.0	374.0	25.0	M12/M16 <sup>1</sup> / <sub>2</sub> "	1.69	2	114770
LKS 19-273	273.0	440.0	23.0	M16	2.77	2	114771