

60/40/90°

Fixing Bracket MW S HCP

Group: 1826

Application

Designed for general mounting purposes as a direct lateral attachment link integrated in binding and bridging beams of concrete or wood, and for similar applications. It may serve as a connecting bracket for framework structures consisting of channels.

Technical Data

Type	Working load	Sprinkler System
60/40/90°	7.5 kN	≤ DN 150
90/60/90°	7.5 kN	≤ DN 150

Material: Steel, HCP

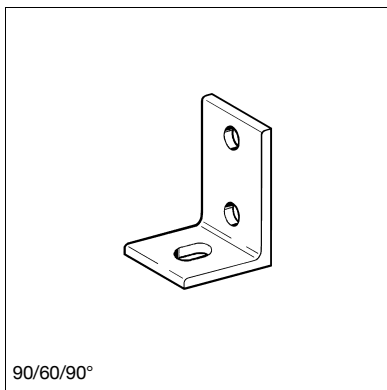

90/60/90°

Type	Angle steel profile DIN 1029	B [mm]	b [mm]	d [mm]	s [mm]	W [kg]	Quantity [pack]	Part number
60/40/90°	60/40/6	40	20	13	-	0.18	25	162063
90/60/90°	90/60/6	40	15	13	50	0.26	25	162072

