

### Clamping Unit KL

Group: 1357

#### Application

Used for assembling double channels made from Sikla Channels with slot pattern III or IV, i.e. with a minimum material thickness of 2.0 mm. This system could be used for pre-assembly in a workshop also. A torque wrench is required in order to ensure that the static values indicated on page 3-7 are achieved.

**Attention:** These values are only guaranteed when using Sikla Channels.

#### Scope of delivery

Consists of forming plate, pressure plate and a hexagon socket bolt M8 (DIN 7991)

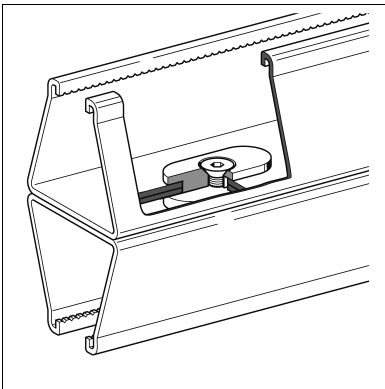

#### Installation

Max. spacing between connecting points is 500 mm, with one point at each end of the channel section. Required number of Clamping Units: channel 2m = 5 pcs., channel 6m = 13 pcs. For Channel 41/21/2,0 no connecting elements, like channels nuts, etc. could be placed directly above the connectors. Torque: M = 25 Nm

#### Technical Data

Material: Malleable cast iron, electro-galvanised

Type	For Sikla Channel	W [kg]	Quantity [pack]	Part number
KL 1	41/21/2.0 bis 41-75/75/3.0	0.11	50	<b>118055</b>