

Assembly Set MS 5P MA

Group: A640

Application

Element for connecting Beam Bracket TKO, Angled Beam Bracket SKO, End Support WBD or Pivot Joint GE F to a beam section.

Scope of delivery

Type	Beam Clip [Quantity]	Support plate [Quantity]	Stop plate [Quantity]	HR trimming* [Quantity]
M12 MA S	4 x M12	4 x M12	4 x M12	4 x M12 x 80
M16 MA S	4 x M16	4 x M16	4 x M16	4 x M16 x 100

* HR trimming according EN 14399-3 consisting of: Hexagon bolt M12 or M16, 2 washers, 1 hexagon nut

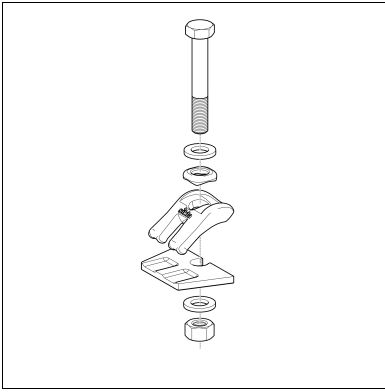

Installation

1. Position stop plate on component to be mounted.
2. Position the Beam Clip with the slit side into the indentations of the stop plate and with the lug on the steel girder.
3. Install support plate and HR trimming and tighten accordingly.

The support plate secures a rectangular assembly of the bolt and prevents its shifting or bending stress. In conjunction with the HR trimming a continuous and predictable preload force is guaranteed. The stop plate ensures a tight fit of the Beam Clip.

Technical Data

Type	Size range [mm]	Tightening torque M_A [Nm] / plus 90° revolution	F_y permitted per Beam Clip [kN]	Shear force load capacity F_z per Set = 4 Beam Clips [kN]
M12 MA S	1 - 30	60 / 90°	32.9	15.1 *
M16 MA S	4 - 40	140 / 90°	39.1	16.7 *

* The specified data relate to the worst case with flange thicknesses 30 mm (M12) or 40 mm (M16) as well as a coefficient of adhesion $\mu_{adhesion} = 0.20$. A possibly operating tensile force F_y isn't included.

Material: Steel, HCP

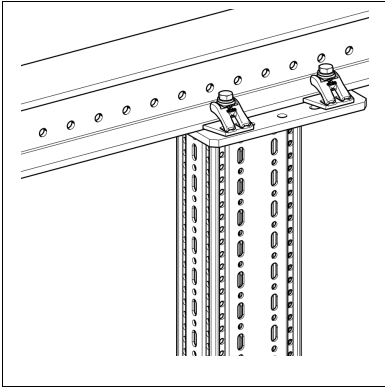

Type	W [kg]	Qty. [set]	Part number
M12 MA S	1.6	10	114886
M16 MA S	2.8	10	114887

