

## Ratio LS

Group: 1245

### Application

Two-piece pipe clamp with double threaded nut (M8/M10) for installing pipe systems for M&E services. For soundproof ceiling, floor and wall installations. With time-saving quick-set clip.

From 4" on, or when higher static loads occur, or under reversed bending stress, we recommend the use of a Stabil Pipe Clamp with lining.

### Installation

After pressing together both parts of the clamp, the clamping bolt head must be located behind the angled profiles; then tighten clamping bolt (2 Nm).

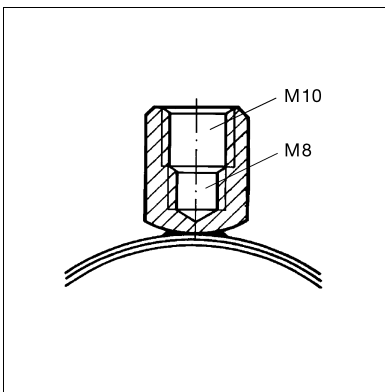

### Technical Data

Size [mm]	Max. perm. working load (tension)
12 - 84	0.60 kN
83 - 90	0.95 kN
108 - 114	1.15 kN

The recommended load is calculated using specific statistical methods relating to break load and is designed to restrict deflection to 1.5 mm or 2 % of the maximum applicable clamping diameter.

Perm. load  $FZ_{perm,fi}$  in case of fire

Size range [mm]	FWD 30 [N]	FWD 60 [N]	FWD 90 [N]	FWD 120 [N]	Deformation $\delta_{max}$ [mm]	Thread $\geq$
12 - 84	290	130	70	50	35	M10
83 - 90	390	210	130	90	31	M10
108 - 114	540	270	170	120	46	M10

Material:

Clamp: Steel, electro-galvanised

Spring element: Spring steel

Sound absorption lining: SBR/EPDM (black) (see chapter "Sound Absorption Products")

Sound absorption: Up to 17 dB(A)

### Approvals / Conformity



This product has been awarded the RAL quality marks "pipe supports" and "fire-tested pipe supports" and is subject to continuous external monitoring according to RAL GZ-655.

Size range [mm]	NB	Thread connections	W [kg]	Quantity [pack]	Part number
12 - 20	1/4" - 3/8"	20 x 1.5	0.05	100	157418
21 - 27	1/2" - 3/4"	20 x 1.5	0.06	100	157427
28 - 35	1"	20 x 1.5	0.07	100	157436
38 - 45	1 1/4"	20 x 1.5	0.09	50	157445
48 - 56	1 1/2"	20 x 1.5	0.09	50	157454
57 - 63	2"	20 x 1.5	0.10	50	157463
64 - 71		20 x 1.5	0.12	25	157472
74 - 84	2 1/2"	20 x 1.5	0.12	25	157481
83 - 90	3"	20 x 2.0	0.16	25	157490
108 - 114	4"	25 x 2.0	0.26	25	157506