

Welding Adapter ASA F 100 Octagon

Group: A828

Application

Welding plate with octagonal insert to receive siFramo section. May be implemented into the structural steel design in anticipation of siFramo-frames or used in situ as a connection element when clamping is not an option but hot works are permitted. The octagonal insert allows for full utilisation of beam section within the space required by the Welding Adapter ASA itself.

Scope of delivery

Mounting Plate 100 with welded on octagonal joint.

Installation

The welding plate of the ASA can be welded directly without previous treatment due to a corrosion-resistant weld-thru coating which is compatible with both the HDG surface of the siFramo section and the health and safety requirements of the welding process. Once the ASA adapter has been connected, the coating may also receive paint without previous treatment. The siFramo section must be connected to the Welding Adapter ASA with 4 x Self Forming Screw FLS.

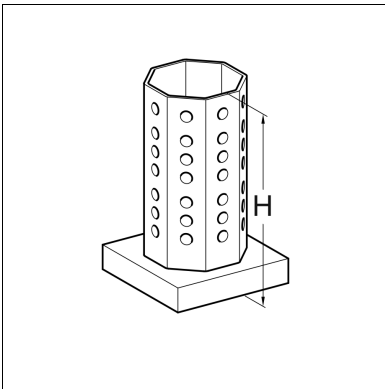

Technical Data

Type	Adapter size H [mm]	Mounting Plate size [mm]
ASA F 100 GPL 8kt	200	120 x 120 x 20

Material: Steel, HCP

Approvals / Conformity

CE mark (Declaration of performance see www.sikla.com/service/downloads)



NEPD-4539-3797-EN

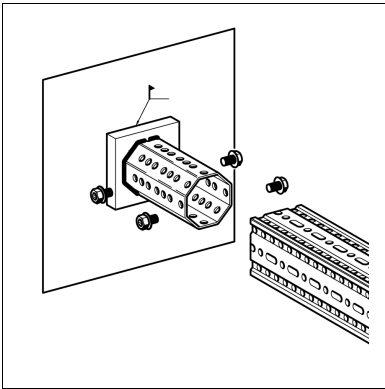

Type	W [kg]	Quantity [pack]	Part number
ASA F 100 GPL 8kt	3.3	1	113080