

Drive Plug AN ss

Group: 1702

Application

Hammerset Anchor for multiple attachment in cracked and single attachment in non-cracked concrete.

Suitable for fixing pipelines, channels, etc. meeting the respective approval requirements. To be used in structural parts under dry indoor conditions, as well as outdoor constructions (including industrial ambience and coastal areas) or damp locations provided no special aggressive conditions are given.

- ◆ No special drill is required
- ◆ Setting Tool for Drive Plug is to be used as setting tool for distance-controlled forced expansion
- ◆ Suitable for put-before assembly

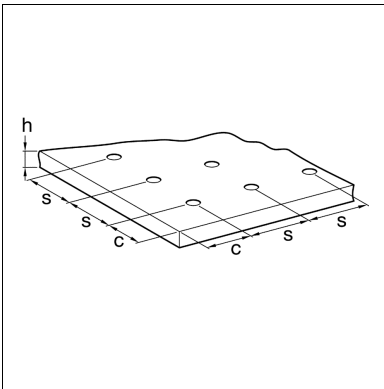

Installation

As setting tool the respective expansion cone for Drive plug is to be used.

The "intelligent" expansion cone facilitates the assembly with drill hole tolerances in the bore hole diameters or with different concrete.

Due to the controlled expansion the needed edge and centre distances are considerably reduced.

Technical Data

General installation data:

Anchor size	M8x30	M8x40	M10	M12	M16
Nominal dia. of drill $d_0 =$ [mm]	10	10	12	15	20
Depth of drill hole $h_0 =$ [mm]	30	40	40	50	65
Tightening torque when anchoring $T_{inst} =$ [Nm]	8	8	15	35	60
Pass-through hole in component to be joined $d_f \leq$ [mm]	9	9	12	14	18
Thread length L_{th} [mm]	13	20	15	18	23
Minimum screw-in depth L_{sdmin} [mm]	9	9	11	13	18
Minimum thickness of component h_{min} [mm]	100	100	130	140	160
Min. centre distance s_{min} [mm]	60	80	100	120	150
Min. edge distance c_{min} [mm]	95	95	135	165	200

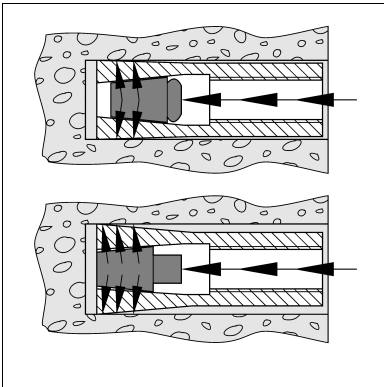

Extract from the approval specifications ETA-05/0117 cracked concrete / multiple fixation of non-bearing systems:

Anchor size	M8x30	M8x40	M10	M12
Perm. load for single anchor C20/25-C50/60 [kN]	1.7	2.0	2.0	2.4
Perm. bending moment (A4-70) M_{perm} [Nm]	11.9	11.9	23.8	42.1
Characteristic centre distance s_{cr} [mm]	180	210	170	170
Characteristic edge distance c_{cr} [mm]	90	105	85	85
Loads under fire exposure				
Perm. load R30 perm. F [kN]	0.9	1.5	1.5	1.5
Perm. load R60 perm. F [kN]	0.9	1.5	1.5	1.5
Perm. load R90 perm. F [kN]	0.9	0.9	1.5	1.5
Perm. load R120 perm. F [kN]	0.5	0.5	1.0	1.2

Extract from approval specifications ETA-10/0257 non-cracked concrete:

Anchor size	M8x30	M8x40	M10	M12	M16
Perm. tensile load C20/25 [kN]	3.8	5.2	5.9	8.3	12.3
Lateral tension perm. $V \geq$ C20/25 [kN]	4.9	4.9	6.1	11.5	19.2
Bending moments perm. M [Nm]	11.9	11.9	23.8	42.1	106.7

The values of the mentioned approvals are valid and could be seen in their latest issue under www.sikla.com/service/downloads.

Material: Stainless steel A4 (316)

Approvals / Conformity

For the multiple fixation of non-structural systems Sikla Approval ETA-10/0258 (M8-M12), for anchorage in non-cracked concrete Sikla Approval ETA-10/0257 (M8-M16), Fire Protection Certification, VdS-conform, FM-Approval \geq M10



¹⁾ Liefertermin auf Anfrage – Ware wird auftragsbezogen beschafft.

Type	Drill hole \varnothing x depth [mm]	Thread \varnothing x length [mm]	W [kg]	Quantity [pack]	Part number
M8 x 30	10 x 30	M8 x 13	0.01	100	104906
M8 x 40	10 x 40	M8 x 20	0.01	100	153593
M10 x 40	12 x 40	M10 x 15	0.02	50	104915
M12 x 50 ¹⁾	15 x 50	M12 x 18	0.04	50	104924
M16 x 65 ¹⁾	20 x 65	M16 x 23	0.10	25	104933