

Drop-In Anchor AN ES

Group: 1401

Application

Drop-In Anchor for single fixing in non-cracked concrete and multiple fixing in cracked concrete. Suitable for fixing pipelines, channels, etc. meeting the respective approval requirements. The anchor must only be used for dry interiors. For damp locations and outdoor constructions the stainless steel version is required.

- ◆ No special drill required
- ◆ Setting tool for distance-controlled forced expansion
- ◆ Suitable for push-through mounting

Installation

As expansion tool use the respective Setting Tool for Drop-In Anchor or the Plug-on Setting Tool ASW. The "intelligent" expansion cone facilitates the mounting with bore dia. tolerances or varying concrete quality. By the controlled deformation of the cone during installation, the needed edge and centre distances are decreasing considerably.

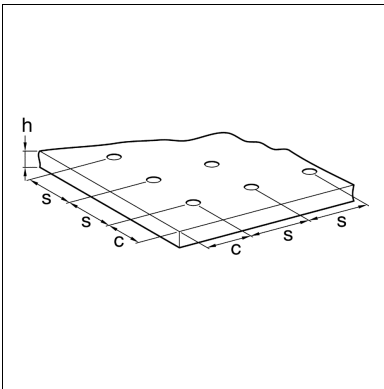

Technical Data

Single fixing:

Extract from application conditions of ETA-10/0257

Permissible loads according to EN 1992-4 without influence of centre and edge distances. Overall safety factor is taken into account (Y_M und Y_F).

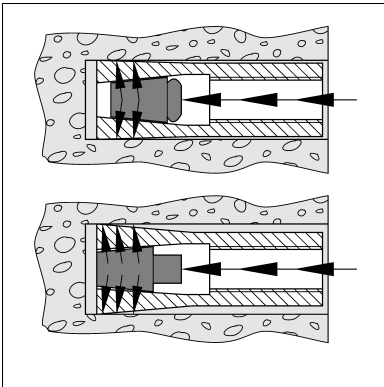

Anchor size	M8x30*	M8x40	M10x30	M10x40	M12x50	M16
Nominal diameter of drill $d_0 =$ [mm]	10	10	12	12	15	20
Depth of bore hole $h_0 =$ [mm]	30	40	30	40	50	65
Installation torque $T_{inst} =$ [Nm]	8	8	15	15	35	60
Diameter of clearance hole in the connecting element $d_f \leq$ [mm]	9	9	12	12	14	18
Thread length L_{th} [mm]	13	20	12	15	18	23
Min. screwing depth L_{smin} [mm]	9	9	10	11	13	18
Min. thickness of concrete slab h_{min} [mm]	100	100	120	120	130	160
Min. centre distance s_{min} [mm]	60	80	100	100	120	150
Min. edge distance c_{min} [mm]	95	95	115	135	165	200
Perm. tensile load in non-cracked concrete (Screw 5.6 up to 8.8)						
C20/25 [kN]	3.2	3.6	3.2	4.9	6.9	10.2
C25/30 [kN]	3.6	3.8	3.6	5.5	7.7	11.4
C30/37 [kN]	3.9	4	3.9	6.0	8.5	12.5
C40/50 [kN]	4.5	4.4	4.5	7.0	9.8	14.5
C50/60 [kN]	5.1	4.7	5.1	7.8	10.9	16.2
Lateral load (Screw 5.6) \geq C20/25 zul. V [kN]	3.8	3.9	3.8	4.1	9	16.8
Lateral load (Screw 5.8) \geq C20/25 zul. V [kN]	3.8	3.9	3.8	4.1	11.1	18
Lateral load (Screw 8.8) \geq C20/25 zul. V [kN]	3.8	3.9	3.8	4.1	11.1	18
Perm. bending moment (Screw 5.6) M_{zul} [Nm]	8.1	8.1	15.8	15.8	27.8	71
Perm. bending moment (Screw 5.8) M_{zul} [Nm]	10.9	10.9	21.1	21.1	37.1	94.9
Perm. bending moment (Screw 8.8) M_{zul} [Nm]	17.1	17.1	33.7	34.3	60	152
Charact. centre distance s_{cr} [mm]	90	120	90	120	150	195
Charact. edge distance c_{cr} [mm]	45	60	45	60	75	97.5
Loads under fire exposure steel \geq 5.6						
Perm. load R30 perm. F [kN]	0.9	1.8	0.9	1.8	3.2	4.7
Perm. load R60 perm. F [kN]	0.9	1.3	0.9	1.8	3.1	4.7
Perm. load R90 perm. F [kN]	0.8	0.8	0.9	1.2	1.8	3.3
Perm. load R120 perm. F [kN]	0.5	0.5	0.7	0.8	1.2	2.2

* Application for indetermined static systems

Multiple fixing:

Extract from application conditions of ETA-10/0258

For the multiple use for non-structural applications. Permissible loads according to EN 1992-4 without influence of centre and edge distances. The overall safety factor is taken into account (γ_M und γ_F).

The maximum permissible load per fixing point may be less than the permissible load of the anchor, depending on national regulations.

Anchor size	M8x25	M8x30	M8x40
Nominal diameter of drill d_0 [mm]	10	10	10
Depth of bore hole h_0 [mm]	25	30	40
Installation torque T_{inst} [Nm]	8	8	8
Diameter of clearance hole in the connecting element $d_f \leq$ [mm]	9	9	9
Thread length L_{th} [mm]	12	13	20
Min. screw depth L_{sdmin} [mm]	8	9	9
Standard/Min. thickness of component h_{min1} / h_{min2} [mm]	100/80	100	100
Min. centre distance s_{min} [mm]	50	60	80
Min. edge distance c_{min} [mm]	100	95	95
Perm. tensile load cracked/non-cracked concrete			
C12/15 and C16/20 [kN]	1.2	-	-
C20/25 to C50/60 [kN]	1.9	1.7	2
Perm. bending moment (Steel 4.6) M_{zul} [Nm]	6.4	6.4	6.4
Perm. bending moment (Steel 5.6) M_{zul} [Nm]	8.1	8.1	8.1
Perm. bending moment (Steel 5.8) M_{zul} [Nm]	10.9	10.9	10.9
Perm. bending moment (Steel 8.8) M_{zul} [Nm]	17.1	17.1	17.1
Charact. centre distance s_{cr} [mm]	75	180	210
Charact. edge distance c_{cr} [mm]	38	90	105
Loads under fire exposure screw ≥ 4.8			
Perm. load R30 perm.. F [kN]	0.6	0.9	1.1
Perm. load R60 perm. F [kN]	0.6	0.9	0.9
Perm. load R90 perm. F [kN]	0.6	0.6	0.6
Perm. load R120 perm. F [kN]	0.5	0.5	0.5
Loads under fire exposure screw ≥ 5.6			
Perm. load R30 perm. F [kN]	0.6	0.9	1.5
Perm. load R60 perm. F [kN]	0.6	0.9	1.5
Perm. load R90 perm. F [kN]	0.6	0.9	0.9
Perm. load R120 perm. F [kN]	0.5	0.5	0.5
Charact. centre distance $s_{cr,fi}$ [mm]	100	180	210
Charact. edge distance $c_{cr, fi}$ [mm]	50	90	105

Anchor size	M10x25	M10x30	M10x40	M12x25	M12x50	M16
Nominal diameter of drill $d_0 =$ [mm]	12	12	12	15	15	20
Depth of bore hole $h_0 =$ [mm]	25	30	40	25	50	65
Installation torque $T_{inst} =$ [Nm]	15	15	15	35	35	60
Diameter of clearance hole in the connecting element $d_f \leq$ [mm]	12	12	12	14	14	18
Thread length L_{th} [mm]	12	12	15	12	18	23
Min. screw depth L_{smin} [mm]	10	10	11	12	13	18
Standard/Min. thickness of component h_{min1} / h_{min2} [mm]	100/80	120	120	100/80	130	160
Min. centre distance s_{min} [mm]	60	100	100	100	120	150
Min. edge distance c_{min} [mm]	100	115	135	110	165	200
Perm. tensile load cracked/non-cracked concrete						
C12/15 and C16/20 [kN]	1.7	-	-	1.7	-	-
C20/25 to C50/60 [kN]	2.1	2	2	2.1	2.4	6.3
perm. bending moment (Steel 4.6) M_{zul} [Nm]	12.8	12.8	12.8	22.2	22.2	56.9
perm. bending moment (Steel 5.6) M_{zul} [Nm]	15.8	15.8	15.8	27.8	27.8	71
perm. bending moment (Steel 5.8) M_{zul} [Nm]	21.1	21.1	21.1	37.1	37.1	94.9
perm. bending moment (Steel 8.8) M_{zul} [Nm]	34.3	33.7	34.3	60	60	152
Charact. centre distance s_{cr} [mm]	75	230	170	75	170	400
Charact. edge distance c_{cr} [mm]	38	115	85	38	85	200
Loads under fire exposure \geq 4.8						
Perm. load R30 perm. F [kN]	0.6	0.9	1.5	0.6	1.5	4
Perm. load R60 perm. F [kN]	0.6	0.9	1.5	0.6	1.5	4
Perm. load R90 perm. F [kN]	0.6	0.9	1.1	0.6	1.5	3
Perm. load R120 perm. F [kN]	0.5	0.7	0.9	0.5	1.2	2.4
Loads under fire exposure screw \geq 5.6						
Perm. load R30 perm. F [kN]	0.6	0.9	1.5	0.6	1.5	4
Perm. load R60 perm. F [kN]	0.6	0.9	1.5	0.6	1.5	4
Perm. load R90 perm. F [kN]	0.6	0.9	1.5	0.6	1.5	3.7
Perm. load R120 perm. F [kN]	0.5	0.7	1.0	0.5	1.2	2.4
Charact. centre distance $s_{cr,fi}$ [mm]	100	170	170	100	200	400
Charact. edge distance $c_{cr, fi}$ [mm]	50	85	85	50	100	200

Valid are the values of the mentioned approval which can be seen on our website www.sikla.com/downloads.

Material: Steel, galvanised

Approvals / Conformity

For the multiple use for non-structural applications Sikla approval ETA-10/0258 (M8 - M12), for installation in non-cracked concrete Sikla approval ETA-10/0257, fire protection testing, VdS-conform, FM-Approval \geq M10



¹⁾ Delivery date on request - goods are procured order-related.

Type	Drill hole Ø x depth [mm]	Thread Ø x length [mm]	W [kg]	Quantity [pack]	Part number
ES M8 x 25	10 x 25	M8 x 12	0.01	100	116618
ES M8 x 30	10 x 30	M8 x 13	0.01	100	110467
ES M8 x 40	10 x 40	M8 x 20	0.01	100	110468
ES M10 x 25	12 x 25	M10 x 12	0.02	50	116619
ES M10 x 30	12 x 30	M10 x 12	0.02	50	110506
ES M10 x 40	12 x 40	M10 x 15	0.02	50	110469
ES M12 x 25 ¹⁾	15 x 25	M12 x 12	0.02	50	116620
ES M12 x 50	15 x 50	M12 x 18	0.04	50	110470
ES M16 x 65	20 x 65	M16 x 23	0.10	25	110471