

## Ground Mount System

Group: E400

### Application

Cost-effective ground mount system for large-scale PV plants. Substantial overall cost reduction due to the foundation technology based on pile-driven supports. On the one hand wind and snow loads are transferred into the soil by the friction between the post and the soil and on the other hand via the pressure at the peak end of the post due to compressed rocky soil inside the post, creating a safe foundation. The buckling resistant geometry of the section prevents torsional deformation of the posts in case of hitting obstacles during installation.

Selection, configuration and design of the structural system components are the result of the individual analysis of the project, which guarantee the most effective use of material.

### Benefits:

- ◆ No soil sealing
- ◆ Extremely quick mounting time
- ◆ Simple assembly
- ◆ Prefabricated system
- ◆ Perfectly synchronised system components - only 6 parts required
- ◆ High durability due to excellent HCP surface protection
- ◆ Optimum utilisation of material resources
- ◆ Mounting time up to 1 km length per day
- ◆ Simple adjustment options during assembly by means of defined friction
- ◆ Simple, cost-saving deconstruction

### Scope of delivery

Ground mount system comprising post, t-bar, channel, module clamps, screws, plus additional strut (optionally required)

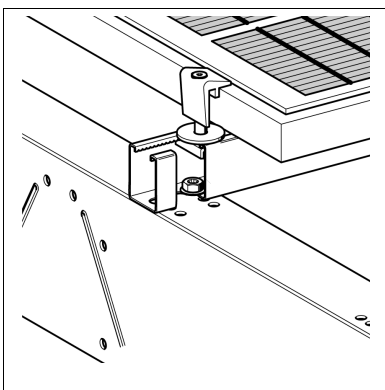
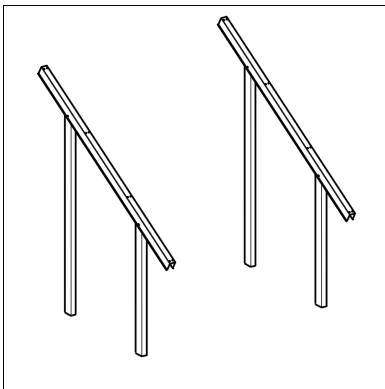
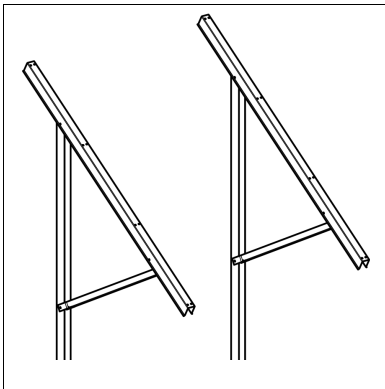

System	Post	T-Bar	Strut
	RAM Solar OAR	Solar OAT	STR Solar OA
Single Post System with bracing	1	1	1
Dual Post System	2	1	-

### Installation

The selection of foundation and design of supporting structure is based on individual structural analysis according to the current state of standardisation and specifications.

1. Drive the posts into the soil. The piling depth is based upon the results of the geological survey.
2. Connect the t-bar onto the post. Screw the guide bolt in the aligned t-bar/post drill hole. Adjust the t-bar according to the pitch angle and tighten with the remaining screws.
3. Place the horizontal channels on top of the t-bars and fix them in position. Install the channel connectors and fix them with screws.
4. Click in place the module clamps. Alternatively, with shorter tables, steps 3 and 4 could be executed still in horizontal position before adjustment of the inclination.
5. Place the modules onto the construction, position them and tighten the module clamps.

### Technical Data

Material: Steel  
Surface: HCP

Type	Weight [kg/m]	Qty. [m]	W [kg]	Quantity [pack]	Part number
Post RAM Solar OAL 3 mm HCP	7.68	1			<b>113167</b>
T-Bar Solar OAL 3 mm HCP	6.31	1			<b>113168</b>
Strut STR Solar OAL 3 mm HCP			5.38	1	<b>113166</b>